

A3

This drawing and/or any technical information relating to it issued in strict confidence and may not be reproduced or used for manufacture without written permission. Upon receipt of which it is the users responsibility to seek confirmation of any dimensions and production tolerances.

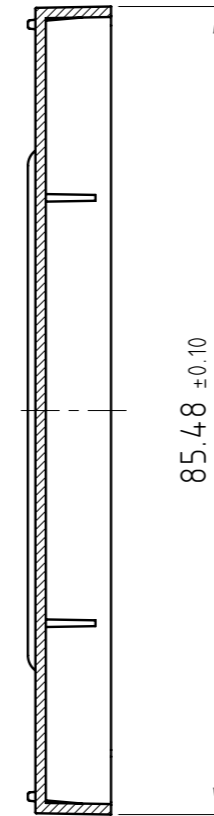

SECTION B-B

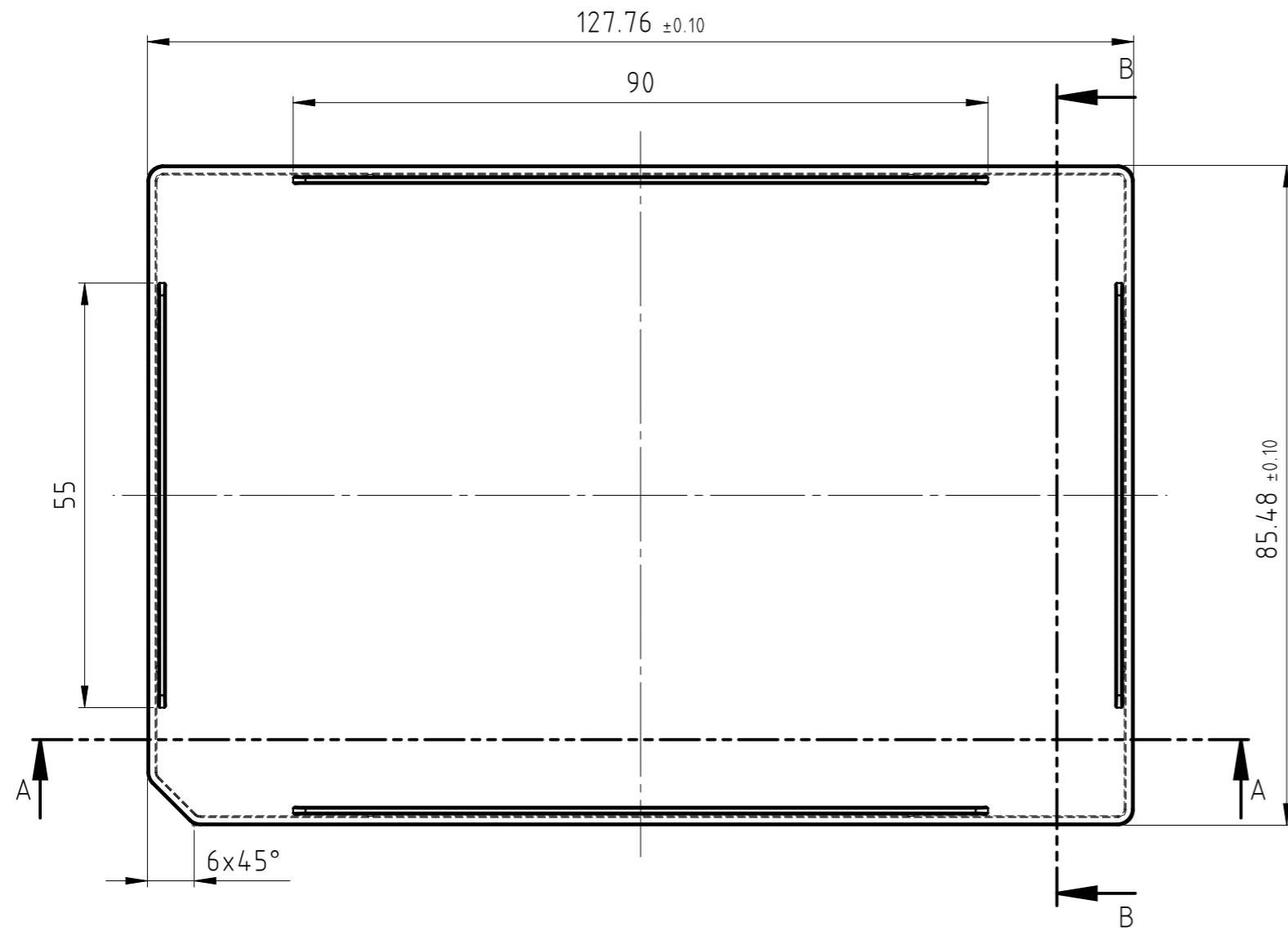
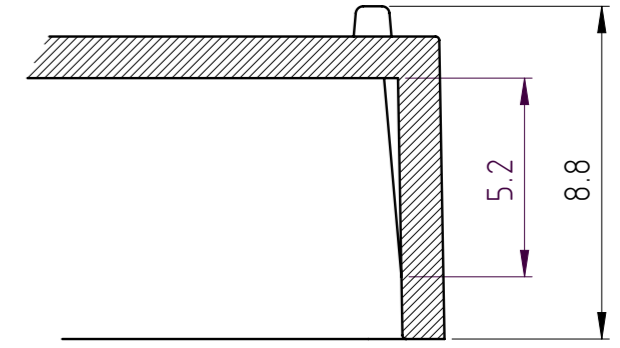

DETAIL F  
SCALE 5 : 1

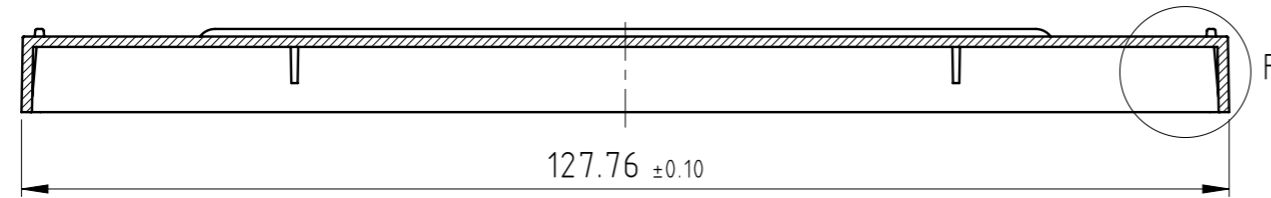

SECTION A-A

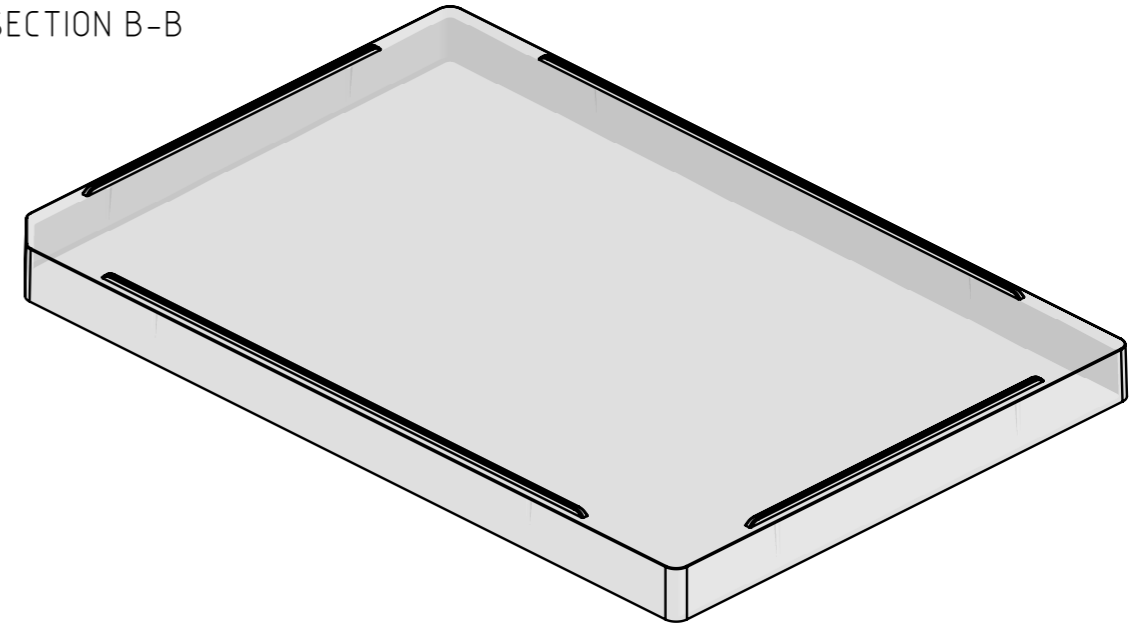

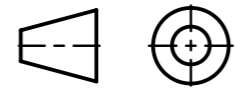
 From Brooks LIFE SCIENCES  WWW.4ti.co.uk	 DO NOT SCALE  IF IN DOUBT ASK	CUSTOMER:	SIGNATURE:	DRAWN: KIRAN SANDHU	TITLE: NGS Universal LID - Version 3 MARKETING DRAWING
		CUSTOMER DRG No.:	ISSUE:	DATE: 04/03/2020	DRAWING No.: 4TI-0288
		MATERIAL: POLYSTYRENE		CHECKED BY: HANNA OLDFIELD	
		TOLERANCES:		DATE:	SHEET No.: 1 OF 1
GENERAL TOLERANCES (UNLESS OTHERWISE STATED)		0 ±0.15 0.0 ±0.05 0.00 ±0.02	SCALE:		
		ANGULAR ±0°30'	(ALL DIMENSIONS IN MILLIMETRES)		